



- **PC104PLUS bus compatible**
- **IPC1553 - Next generation 1553 core**
- **Programmable as Bus Controller or Remote Terminal or Monitor Terminal**
- **Up to 3 Dual Redundant MIL-STD-1553B channels**
- **31 Remote Terminal Controls**
- **Direct or Transformer Coupled**
- **Software Driver support for a host of Operating systems / Environments**

OVERVIEW

The AT-PC104PLUS-1553 card provides a flexible, Single function, dual redundant MIL-STD-1553B interface to the PC/104PLUS embedded bus. It provides the highest level of performance & flexibility for MIL-STD-1553B protocol on the PC/104PLUS bus. The AT-PC104PLUS-1553 offers Simulation, Monitoring functions. The card comes integrated with powerful software that reduces application development time. All data bus functionality is supported by our advanced API (Application Programming Interface).

HARDWARE

The AT-PC104PLUS-1553 card's single function architecture emulates a Bus Controller or 31 Remote Terminal or Monitor Terminal modes. Standard features include Programmable coupling and bus termination, extensive BC frame structures, error detection, RT Status Bit and Mode Code responses, along with advanced BC functionality. Polling and interrupt generation is also provided. The advanced BC architecture provides a high degree of flexibility and autonomy by providing Major and Minor frame schedule control, streaming data interface, asynchronous message insertion, bulk data transfers, double buffering, message retry, bus switching strategies, and data logging, and fault reporting. The RT architecture provides flexibility in meeting all common MIL-STD-1553 protocols while emulating up to 31 RT addresses on one 1553 channel. The card includes a message monitor mode and a combined Multi-RT/ MT mode where the MT will monitor all 1553 communications on the bus, including the 1553 channel's assigned RT addresses. The Bus Monitor mode provides complete error detection on 100% fully loaded buses, advanced error detection to isolate faults at a particular word with in a 1553 message.

Transformer and Direct Coupling

The card can be configured to work either in the transformer-coupled mode or in the direct-coupled mode. Jumpers are provided on the card to select the mode. It is configured to work in the transformer-coupled mode by default.

SOFTWARE

The AT-PC104PLUS-1553 software includes:

- > Bus Monitor
- > Drivers & APIs

Bus Monitor

- Record and replay of data
- Replay with rate selection
- Message identifier
- Multi console at a time
- Bus ideal time analyzer
- Filtering option up to sub address
- Message sampling option

Drivers & APIs

The cards come with a powerful set of library functions to access the entire MIL-STD-1553B functionality. The drivers are designed in a modular fashion consisting of component functions and application functions. The user's test program can be developed with few calls to the driver by using the set of application functions provided. Driver and high-level API libraries for Windows XP are available. Sample programs for BC, RT, MT modes are included.

AT-PC104PLUS-1553

MIL-STD-1553B PC104PLUS CARD

PRODUCT SPECIFICATIONS

MIL-STD-1553

- Programmable as Bus Controller or Remote Terminal or Monitor Terminal
- Up to 3 Dual Redundant MIL-STD-1553B channels
- Message formats BC-RT, RT-BC, RT-RT, Broadcast, System Control
- Direct or Transformer coupled
- Software Programmable RT Address

IPC1553

- IPC1553 is AT'S next generation 1553 Core, with BC, Multi-RT, MT, BC/MT, Multi-RT/MT operating modes

1553 Bus Controller

- Automatic retries on alternate bus
- Inter-message gap times up to 65.5ms
- Programmable response timeout up to 130 µs
- Minor/Major Frame Scheduling to Control timing of 1553 messages
- Modify Messages or Data while BC is running
- Detects and Reports 1553 Errors
- Flexible support for data streaming or bulk data transfer

1553 Remote Terminal

- Programmable command illegalization
- 31 Remote Terminal Controls
- Programmable Single Message or double buffering or circular buffering
- BUSY Bit programmable by sub address
- Alphanumeric message ID

1553 Monitor Terminal

- Word monitor per word basis
- Selective message monitor & time stamping
- Dynamic data update
- Message Periodicity
- Bus error status
- Bus load
- Unique Message identifier
- Record and Replay option
- Message identifier
- Advanced Bus Error Detection to Isolate Bus Failures

Software Support

- Driver and high-level API libraries for Windows XP
- Sample applications provided

Physical

- Standard PC/104PLUS card size (3.55in x 3.75in)

Environmental

- Operating temperature: 0° C to +50° C
- Storage temperature: -20° C to +70° C

Power

- +5 +/- 5% VDC supply

Warranty

- 1 year limited warranty

ORDERING INFORMATION

Hardware Selection

AT-PC104PLUS-1553- Controller-Channels-DIO

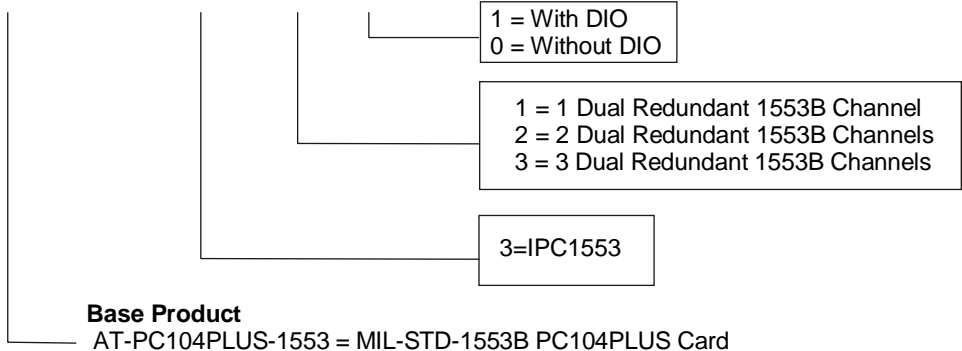

- Contact sales for support for other Operating Systems
- Contact sales for environmental options



ADTECElectronic Instruments Pvt Ltd
563/1, PRERANA TOWERS, Ranka Colony
Road, Off BG Road, Bengaluru 560076
Email : sales@adtec.in
Website : www.adtec.in

Distributor/Reseller